

Disk Check Valve PN 40
DN 15 - 150 (1/2" - 6")
Stainless Steel Construction

Index



Fig. VR-316
WAFER
Face to face dimensions
EN 558-1 Series 49



Authorized Distributor



Disk Check Valve PN 40

DN 15 - 150 (1/2" - 6")

Parts and materials, Dimensions

Parts and materials

DN 15 to DN 50

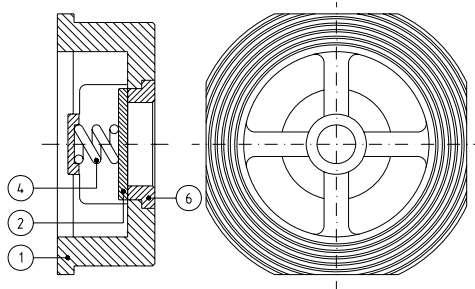

DN 65 to DN 100

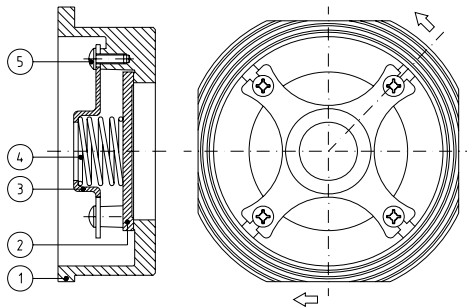

DN 125 & DN 150

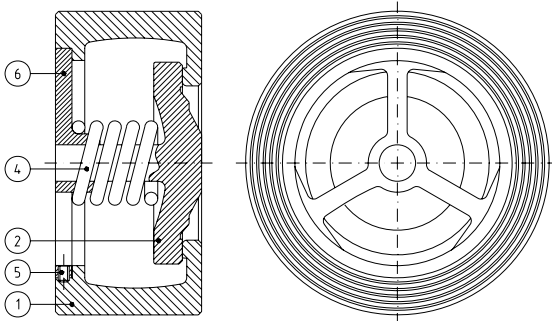

Dimensions

DN 15 to DN 50

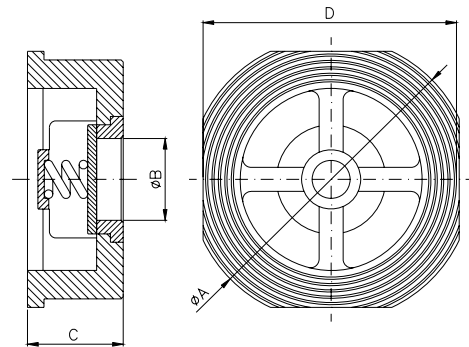

DN 65 to DN 100

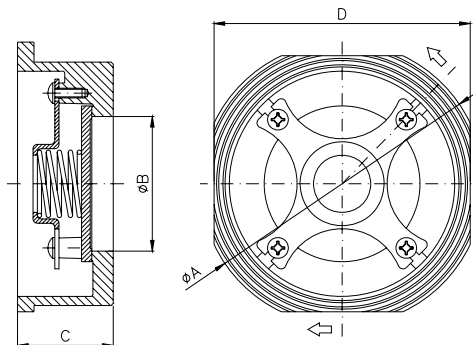

DN 125 & DN 150

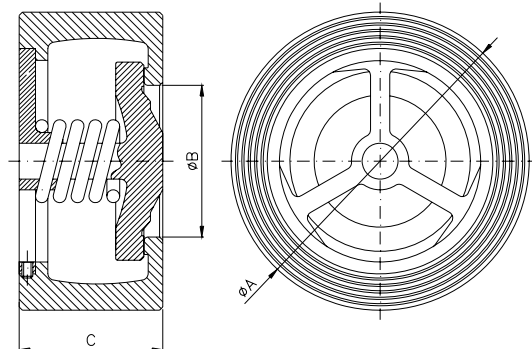

Item	Description	Material
1	Body	1.4408
2	Disc	1.4408
3	Cap	1.4408
4	Spring	AISI 316
5	Screw	AISI 316
6	Insert	1.4408

DN	ØA	ØB	C	D	WEIGHT	ASSEM. BETWEEN FL. ANSI-150
15 (1/2")	53	15	16	45	0,1	OK
20 (3/4")	63	20	19	55	0,16	OK
25 (1")	73	25	22	65	0,28	OK
32 (1 1/4")	84	32	28	78	0,52	--
40 (1 1/2")	94	38	31,5	89	0,7	NO
50 (2")	107	50	40	98	1,1	OK
65 (2 1/2")	126	62	46	118	1,58	OK
80 (3")	144	77	50	134	1,76	OK
100 (4")	162	96	60	154	3,3	OK
125 (5")	194	112	90	---	8	--
150 (6")	220	132	106	---	12	OK

(*) Dimensions in mm and weight in kg.

Authorized Distributor





Disk Check Valve PN 40

DN 15 - 150 (1/2" - 6")

Opening Pressure, KV, P&T Rating

Opening pressure in mbar

VALVE SIZE	Direction of the fluid			VALVE SIZE	Direction of the fluid		
	↑	↓	→		↑	↓	→
DN 15 (1/2")	25	21	23	DN 65 (1 1/2")	31	21	25
DN 20 (3/4")	25	21	23	DN 80 (3")	32	21	26
DN 25 (1")	25	21	23	DN 100 (4")	33	21	27
DN 32 (1 1/4")	27	21	24	DN 125 (5")	31	10	20,5
DN 40 (1 1/2")	29	21	25	DN 150 (6")	33	10	21,2
DN 50 (2")	29	21	25				

Kv Values in m3/h

VALVE SIZE	Kv	VALVE SIZE	Kv
DN 15	8	DN 65	162
DN 20	21	DN 80	223
DN 25	32	DN 100	373
DN 32	45	DN 125	2552
DN 40	67	DN 150	3726
DN 50	109		

Pressure-Temperature

P Bar

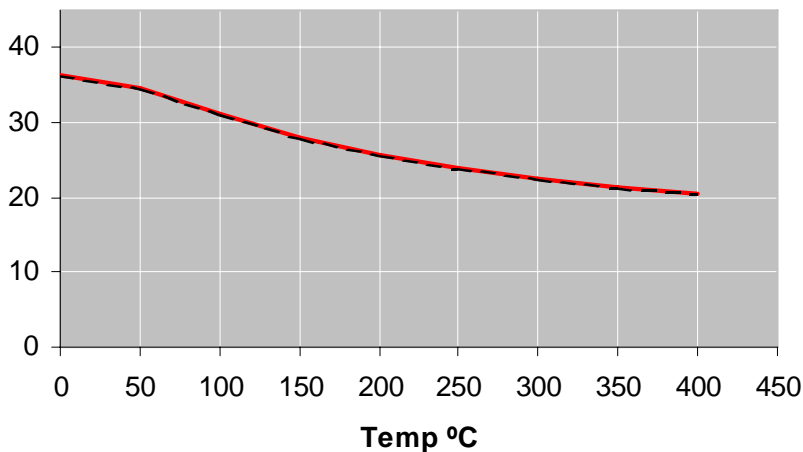

Authorized Distributor

